

Technical conditions

Tube gas fired infrared radiant heater

KM 10-1; KM 15-1; KM 22,5-1; KM 30-1; KM 36-1; KM 45-1

Attachment B1

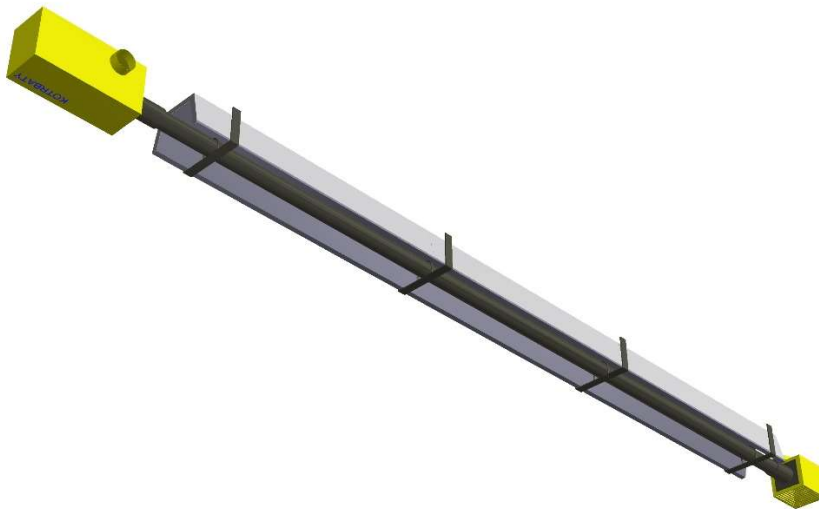

Assembly guide for tube radiant heaters KM-1 5 meter long

REGULATIONS and WARNINGS:

Installation, assembly, repair work on gas and gas supply facilities can only be carried out by qualified personnel of an authorized organization (In CZ - Decree No. 458/2000 Sb.) During installation, the technical and safety regulations (relevant standards, regulations, etc.) must be observed. The installation must be carried out according to the design documentation and the relevant standards.

BEFORE INSTALLATION, CHECK IF THE LOCAL CONDITIONS OF FUEL DISTRIBUTION, FUEL FEATURES, PRESSURE AND SETUP OF THE APPLIANCE ARE COMPATIBLE!



The infrared heater may only be commissioned by a Kotrbatý company service technician or a technician certified by Kotrbatý company for this purpose. **The commissioning of the radiant heater can be done only after revision of electro and gas piping.**



The manufacturer is not responsible for damage caused by unprofessional or unauthorized assembly. When installing radiant heaters, it is the duty of the assembly organization to ensure the full safety of workers and persons moving around the installation site and to take all precautions to prevent damage to surrounding devices. Work actions performed at height above 1.5 m are classified as **work at heights** with all the mandatory consequences!

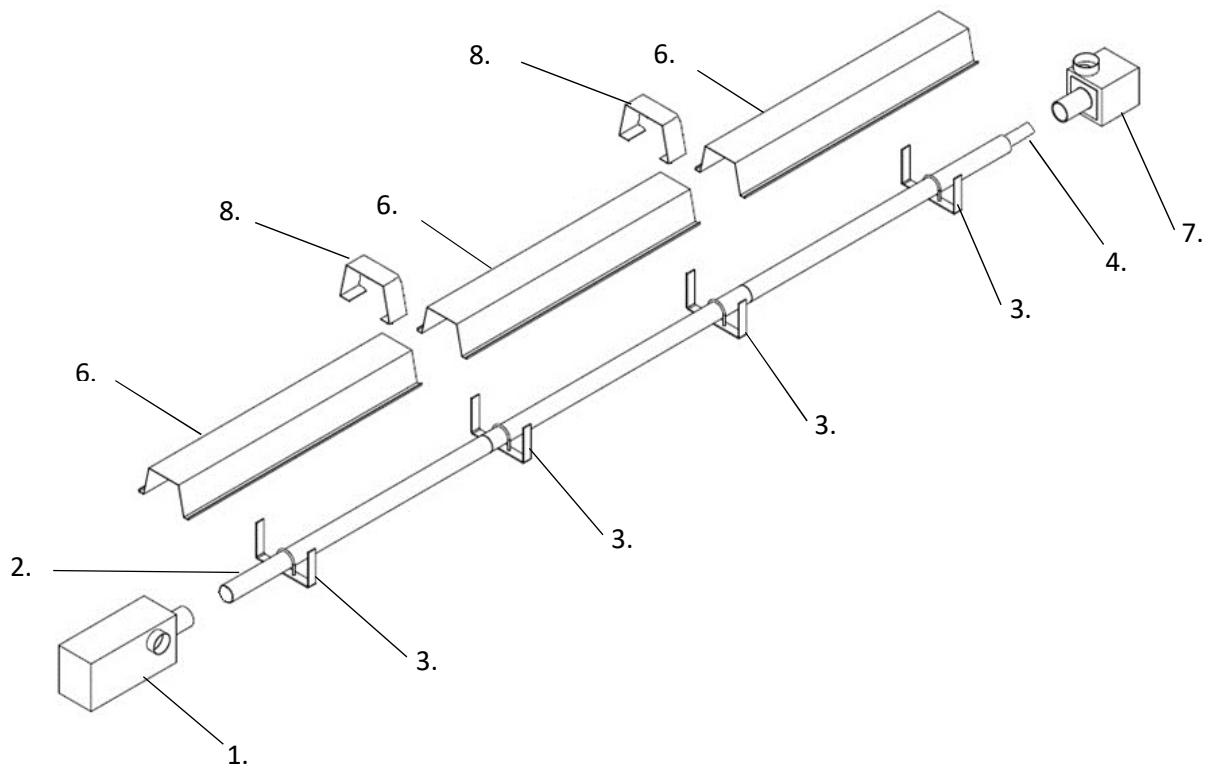

Fig.I

Legend:

1. Burner box
2. Heating surface - tube
3. Hangers
4. Baffle
5. Joints – Tube heating surface
(KM with divided heating surface only)
6. Stainless-steel reflector *(order based with or without insulation)*
7. Fan box
8. Insulation clip *(version with insulation only)*

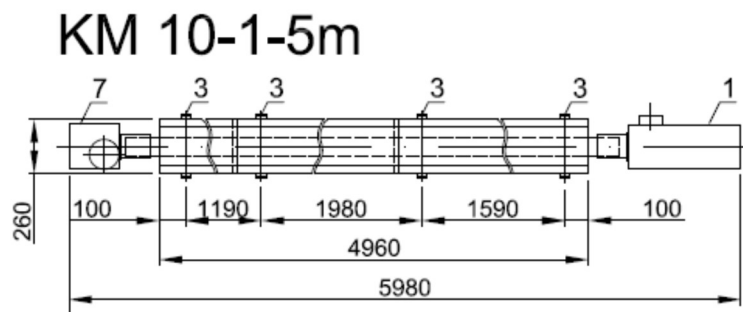

Fig.II

- 1) Check, if delivery contains all parts according to specification and **fig.I, resp. II**

Delivery contain electrical connecting cables with special connectors – keep for commissioning technician

- 2) Fasten to the ceiling (or other construction) with sufficient load capability required number of suspension points with nodal chain long enough to be able to suspend the heater to demanded height. Distance between hangers **(3)** according to **fig. II**.

NOTE - it is recommended to leave 15 cm longer suspensions for easier adjustment of water level later

- 3) Move the loose hangers **(3)** from the transport position to the positions according to **fig.II** and demanded heater type.

NOTE ! - The first hanger from the burner is from manufacture welded to position!



- a) Tube paint is not abrasion resistant so work carefully!
- b) Hangers **(3)** with exception of the first one are all loose with defined spaces around the tube - **DO NOT TIGHT THEM!**

- 4) Lift the heating surface tube **(2)** with allocated hangers **(3)** to the defined height

ATTENTION!



- a) Underlay the heating surface in the touching point before lifting with some cardboard paper or textile, paint is not abrasion resistant!
- b) It is necessary to perform the lifting uniformly and protect the heating surface from falling down

- 5) Attach the prepared nodal chains to the screws on heating surface's hangers. Done by screws M8, which are located on the hangers **(3)**. **The eye on the nodal chain has to be always secured by second nut M8**
- 6) Align all the parts of the heating surface **(2)** into one water level using spirit level
- 7) Check water level and demanded height of suspension **(2)**

- 8) Insert the baffle (4) into the part of FAN tube (2) according to fig. I
- 9) Locate the stainless-steel reflectors (6):



Before installation, it is necessary to check whether the protective foil has been removed from the stainless-steel cover.

- a) First fix the front reflector (6) on the side with fixed hanger (3)
 - b) Tight the reflector to the first hanger (3) by given screws (holes are located on the reflector in the bottom bend in about 100 mm from the side)
 - c) Connect the other reflectors (6) with two screws and pre-drilled holes in bottom bend of the reflector (6) (screws can be found in delivered accessories)
- 10) Locate the burner box (1):
 - a) Thread the burner box (1) on the tube (2) on the side of the first fixed hanger (3), the window screen is located to the bottom
 - b) Mark the centre point through the nut on the tube (2)
 - c) Remove the burner box (1) and in one wall of the tube (2) drill a hole of inside diameter $\varnothing 8,5$ mm
 - d) Locate the burner box (1) back on the tube (2) and secure it by screw M10
 - e) Connect the safety chain (between two nuts) to the screw M8 at the end part of the burner box (1). The second end fix to the nodal chain suspending the first hanger (3)



Safety chain shall not be tight but loose

- 11) Locate the fan box (7):
 - a) Thread the fan box (7) on the tube (2) so to position the exhaust flange upwards
 - b) Through the nut mark the centre point on the tube (2)
 - c) Remove the fan box (7) and in one wall of the tube (2) drill a hole of inside diameter $\varnothing 8,5$ mm
 - d) Thread the fan box (7) back on the tube (2) and secure it by screw M10
 - e) Connect the safety chain (between two nuts) to the screw M8 at the end part of the fan box (7). Fix the second end also to the nodal chain suspending the last hanger (3)



Safety chain shall not be tight but loose

- 12) Hang and screw the armoured tube delivered in several parts
 - a) Push the tubes through the sleeves which are on the hanger brackets.(3)
 - b) Tight the sleeves one by one right after screwing the next part.
 - c) Insert the delivered electric cable through the armoured tube. The electric cable is used for boxes connection (1) a (7).
 - d) The end connectors are installed by the service technician while the radiant heaters commissioning.

13) Assembly of gas hose:

- a) Connect the heater to the gas net by suitable gas hose



Instructions of the gas hose manufacturer shall be followed!

- b) Connect one end of the hose to the cock valve on the gas piping. Seal the connection
c) The end of the hose with union nut is to be connected to the threaded end on the burner box (1)



ATTENTION!

There shall be placed the sealing from delivered accessories between union nut and the threaded end on the burner box (1)!

- d) It is important to assembly the gas hose so not to create thrust force to the heater!
e) At the end perform thorough gas leakage test of all the joints

14) Electro assembly:

- a) Install an ACIDUR distribution box with an inner ring at a distance of max. 1 m from the radiant heater housing
b) Connect the corresponding cables to the particular ACIDUR distribution box according to the electrical wiring diagram of the control box
c) If common cable routes with other power cables (e.g. crane, machine, etc.) are proposed from the control box to the radiant heater, it is recommended to use shielded cables such as JYTY instead of standard CYKY cables. The reason for this is to prevent undesired induction of voltage and thus caused faults in operation of emitters. Please contact us if necessary!



Connection between distribution box ACIDUR and heater's burner box is performed by the service technician while commissioning the radiant heater.

- 15) The installation of the flue gas tube is done next and eventually combustion air inlet as well according to the project documentation.