

INFRARED GAS FIRED TUBE HEATER

KM 10-U; KM 15-U; KM 22,5-U; KM 30-U;

KM 36-U; KM 45-U



Technical conditions



Safety instructions
Construction of heaters
Technical data
Assembly
Operation, maintenance
Service, control

KOTRBATÝ V.M.Z. spol. s r.o.

Design & Sales

Polívkova 926/30, 158 00 Praha 5, Czech Republic, tel.: +420 245 005 921, email: kotrbaty@kotrbaty.cz

Manufacture & service

Sdružená 1788, 393 01 Pelhřimov, Czech Republic, tel.: +420 564 571 520, email: vyroba@kotrbaty.cz

	Page
Table of contents:	
1. Introduction	3
2. Symbols used in documentation	3
3. Safety instructions	3
3.1 Assembly instructions	4
3.2 Instructions for operator and operation staff	4
3.3 Instructions for inspections and revisions	4
3.4 Repairs. Spare parts	5
3.5 Impermissible manner of operation	5
3.6 Evaluation of residual risks	5
4. Type, description	6
5. Intended use	6
6. Electrical wiring diagram	7
7. Function of infrared heater	8
8. Construction of infrared heater	8
9. Basic dimensions of individual infrared heaters	10
10. Technical data	12
11. Heater's suspension	13
11.1 Minimum suspension height	13
11.2 Safety distances	14
12. Gas connection	15
13. Scope of delivery	15
14. Heater's assembly	15
15. Flue gas venting	15
16. Combustion air intake	17
17. Infrared heater as a C – type appliance	17
18. Maximum length of flue gas venting and combustion air inlet	19
19. Transportation. Storage	19
20. Disposal of packaging and product after service life	20
21. Inspections and revisions	20
22. Spare parts	21
23. Operation	22
24. Local operation rules	23
25. Contacts	25
26. Notifications	26
27. Mandatory info – Commission Regulation (EU) 2015/1188	26

Separate attachments:

Attachment A – Heaters' documentation

(nameplate, service report, warranty list, test protocol)

Attachment B1 – Assembly guide for tube radiant heaters KM-U length from 3 to 6 meters

Attachment B2 – Assembly guide for tube radiant heaters KM-U length 8 and 9 meters

Attachment B3 – Assembly guide for tube radiant heaters KM-U-45 length 10 and 12 meters

1. Introduction

Main principle

Infrared gas fired tube heaters works on a principle of closed system ("U" shaped tube). These heaters achieve needed performance by gas combustion in atmospheric burners, from where the flue gases are routed into the radiant tubes provided with reflexive covers. Surface temperature of the tubes moves in the range between 180 and 560 °C. Radial flue gas ventilator, located at the end of the U-tube, secures sufficient movement of hot air in the tube and concurrently removes flue gases.

These heaters are ideal also for lower halls and for the halls with dusty operation, because it is possible to supply the combustion air from outside. Also, it is suited, with very high efficiency, for wholespace heating. Infrared heaters' heating system is, in comparison with warm-air or convectional heating systems very economical.

Attributes of infrared radiation:

- Infrared radiation spreads straightforwardly, so the heaters could be targeted
- Infrared radiation changes into heat in the absorbent body
- Radiation intensity lowers by square of the distance between radiation source and absorbent body
- Infrared radiation moves through the air without transferring the heat

Main advantages of the infrared heaters:

- Investment savings in comparison to "classical" heating systems
- Savings on operating costs

- Operating readiness
- Possibility of local heating according to the requirements
- Do not whirl dust
- Easy operation
- Easy assembly
- Low noise
- Possibility of regulation

2. Symbols used in documentation



Thorough adherence of the guidelines needed



Prompt warning to use safety and personal protective tools in any case of manipulation with gas fired infrared heater KM



Electric shock hazard, possible risk of a fire during assembly or manipulation with gas fired infrared heater KM

NOTICE!

Important instructions or warning of possible consequences in case these instructions will not be followed

3. Safety instructions

This documentation includes basic guidelines for assembly, operation and service of gas fired infrared heaters, type "KM", manufacturer KOTRBATÝ. Also included are basic technical information, dimensions of each heater and description of each part of the heater.

NOTICE! It is absolutely necessary that the assembly workers, same as the operational staff and operator have read this documentation thoroughly before assembly and commissioning of the heater.

This documentation must always be accessible at the place, where the device is operated. Beside these instructions, it is necessary to follow all applicable regulations, ordinances and technical standards relating to gas and electrical appliance, as gas fired infrared heater belongs to both groups. During assembly, operation and maintenance the staff have to follow all safety rules, including use of personal protective tools.

3.1. Assembly instructions

Installation, assembly and repair work on the gas consumption appliances can be carried out only by qualified workers of authorized organisation. Assembly has to be carried out according to manufacturer's instructions as follows, with respect to applicable regulations and technical standards, including safety rules.



Assembled appliance can be commissioned into the operation only by a service technician of Kotrbatý company, or a technician of approved company, with valid certification for infrared heaters commissioning issued by Kotrbatý.

3.2. Instructions for operator and operation staff

Operator is obliged to authorize in writing those workers, who will be operating gas fired infrared heaters. These workers must be physically and mentally able to do the work, must be over 18 years old and must be trained by service technician of Kotrbatý for operating the heaters. Responsibilities of operator and operation workers arising from applicable regulations, ordinances and technical standards are complemented with requirements given in this documentation. Operator is also obliged to inform all workers working in the area heated with infrared heaters of the necessity of reporting anything unusual related to the operation of heater to the operation worker or authorized personnel of the operator.

NOTICE! Any interventions into the appliance are forbidden, in case of need call service of manufacturer.

3.3. Instructions for inspections and revisions

All gas fired infrared heaters KM is subject to regular inspections and revisions. Appliance inspections can be performed only by operation worker (see article 3.2) or authorized person in case of following safety rules and instructions set by relevant regulation and this documentation.

Appliance revision can be performed only by authorized personnel – revision technicians, following applicable regulations and technical standard. During electrical revision it is necessary to follow instructions given in this documentation to prevent damage of control

automatics.

3.4. Repairs. Spare parts

Repairs of gas fired infrared heaters KM can be performed only by Kotrbatý service technicians or companies authorized by Kotrbatý. It is forbidden to assemble any spare parts into the appliance. Any defective parts have to be changed for original parts by service technician.



It is absolutely necessary to close gas ball valve before the heater and disconnect the appliance power supply – electric shock hazard!!!

NOTICE!

Service technician is approved to maintain operations on the heater only if he is certified to do so by technical supervision authorities and was trained !!

3.5. Impermissible manner of operation

Safe operation of gas fired infrared heater can be guaranteed only if their use is in accordance with regulations, technical standards and instructions given in this documentation.



Given limit values of gas overpressure at the appliance entry (5 kPa) and nominal voltage must not be exceeded.

3.6. Evaluation of residual risks

Even though the gas fired infrared heaters are manufactured in accordance with technical standards and must be operated so, there are some residual risks, about which the operator has to be informed:

- Possible burn through of the radiant tube in the distance of approx. 1,5 m from the burner, due high temperature of the flame. Depends on environment quality, duration of the usage or gas pressure fluctuation. In case of finding burn through, switch off the heater and call service technician to change the radiant tube
- High temperature of radiant tubes and stainless cover – possible burning. If any activity have to be done near the heaters, the appliance should be turned off and at least one hour prior. It is important to inform workers, who will be operating near the heater, about the appliance and secure it from accidentally switching on.
- For suspension of the infrared heaters the surface-treated chains or other appropriate suspensions have to be used, to prevent corrosion, possible tearing and fall of the heater.

NOTICE!

Not following safety rules and instructions may result into very serious endangerment of personnel, buildings, appliance itself or environment. In case of gas leak all the appropriate safety measures have to be done immediately!



WARNING!! Before installation, check if local conditions of fuel distribution, overpressure and appliance settings are compatible! This appliance has to be installed in accordance with applicable regulations and its usage is

allowed only in well ventilated area. It is necessary to read the manual before assembly and operation of the heater!

4. Type, description

Gas fired infrared tube heater KM-U is open fuel appliance (**type B**), which takes combustion air from the area where it is installed, and the flue gases are routed through the flue gas duct system to the external environment. In the operations, where the combustion air has to be supplied from the external environment (for ex. polluted air area, overpressure or negative pressure area) the heater is closed fuel appliance, type C, where the combustion air is supplied by air duct system from the external environment and the flue gases are routed through the flue gas duct system to the external environment. Infrared heater category is II_{2H3B/P}, II_{2E3B/P}, I_{2H}, I_{2E}, fuel natural gas or propane butane.

5. Intended use

Infrared heater is designed for heating of large area objects, industrial halls, production spaces, warehouses, sport halls etc. Features and appliance protection given by its construction have to be in accordance to established external influences in the area where the infrared heater is used.



Infrared heater is designed for standard areas, and must not be installed in area with fire or explosion risk etc. Flue gases from the heater must be routed away from the installation area (into external environment).

Appliances with atmospherical burners in type B must not be installed in rooms, where the negative pressure can be created by the ventilators of air vent appliances! Insufficient supply of combustion air causes incomplete combustion. Because of that, it is necessary to secure sufficient air supply resulting from infraheaters need, hygienic regulations for given building or characteristics of operation carried out in the heated area without considering necessary amount of air for heating. Air supply must be reflected in the design of heating and in the design of heaters for given area.

6. Electrical wiring diagram

MANUAL CONTROL OF ONE HEATER

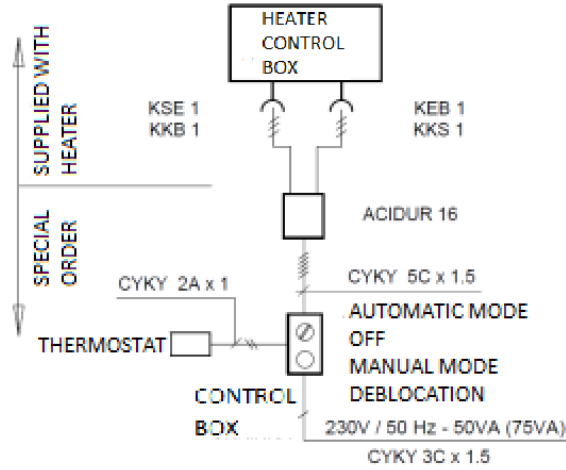

AUTOMATIC CONTROL OF ONE OR MORE HEATERS

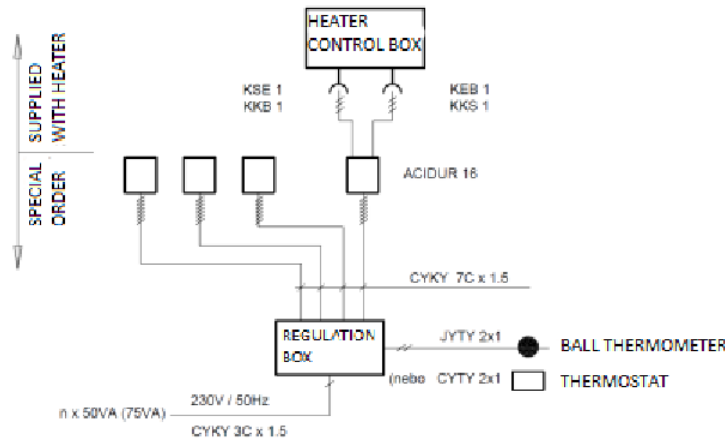

CONNECTION OF REGULATION BOX

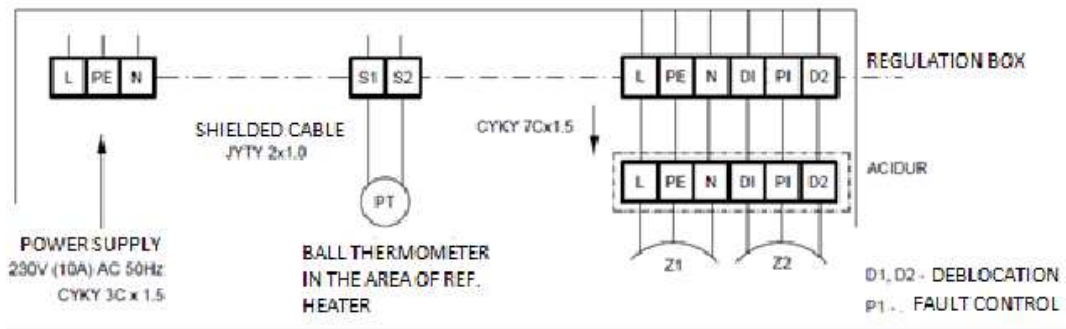

7. Function of infrared heater

Infrared heater KM-U is gas fired heater with deep cover. Heat supply to the space is carried out with radiation of heat tubes. Deep reflector from stainless polished sheet metal directs radiation heat flow into the area beneath the heater.

Independent units, connected to the radiation tubes, are burner box with automatics, gas supply entry, supply pipe for combustion air and ventilator box with ventilator and connection for flue gas outlet. Heater automatics regulates gas pressure ahead of nozzle. It allows constant gas supply into the mixing aspirator of burner.

Infrared heater can be operated manually or automatically (see the wiring diagram). When the electricity is brought from the control box to the control automatics in the burner box, valves of gas fitting opens and on the ignition electrode emerges ignition spark. In case of the fuel blend ignition, ionisation electrode detects flame, starting cycle stops and control automatics holds gas fitting valves opened – heater is in operation. If the fuel blend is not ignited, the flame is lost or in a case of power

loss during starting cycle (5 sec.), gas fitting valves are closed and the heater is outaged („faulty“). For restart it is necessary to deblocate the heater by pushing deblocation button on the control box.

8. Construction of infrared heater

In the figure no. 1 and no. 2 is displayed complete infrared heater consisting of radiation tubes connected into U-shape, which are attached to the suspension by clips. Baffle plate is retracted into the fan tube (returning tube). In needed those tubes are connected by clutch. All of these is covered by deep stainless reflector, established in suspensions. If the infrared heater is insulated, on the external surface of reflector is fastened insulation. There is attached at the end of the tubes the burner box with the automatics (a torch body, gas pressure regulator with electromagnetic valve, gas and air manostat and control automatics). Infrared heater KM-U 45 kW has divided box to a burner box and a fan box. The fan box is attached to the tube which contains the baffle plate.

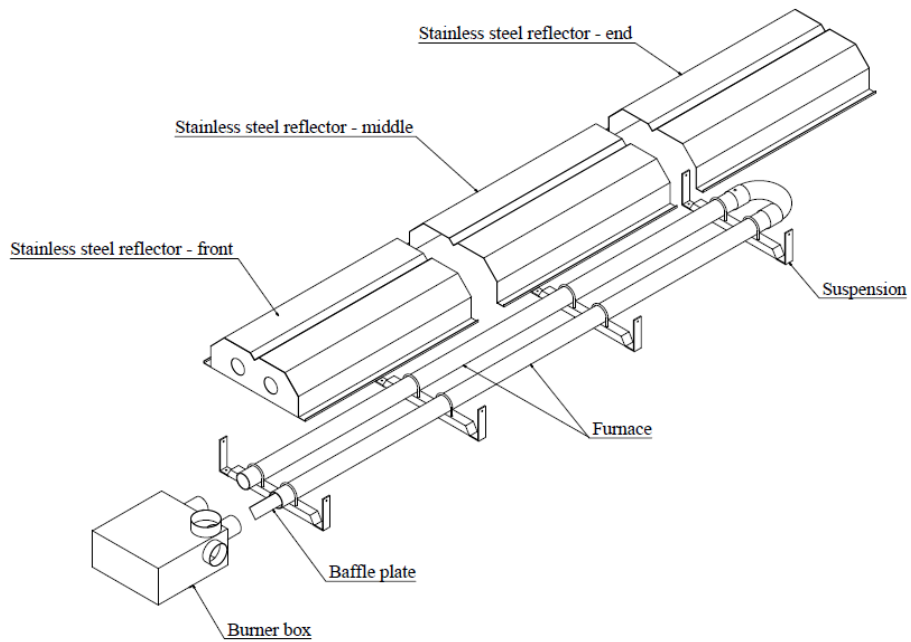

Fig. 1 Infrared heater KM-U with length from 3 to 6 m

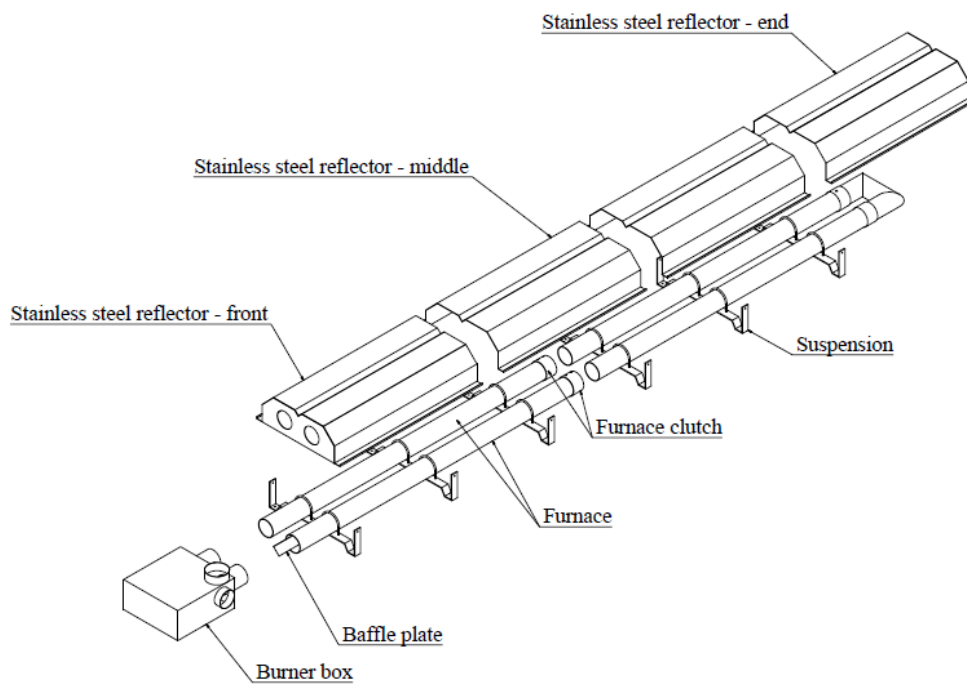

Fig. 2 Infrared heater KM-U with length 8 and 9 m

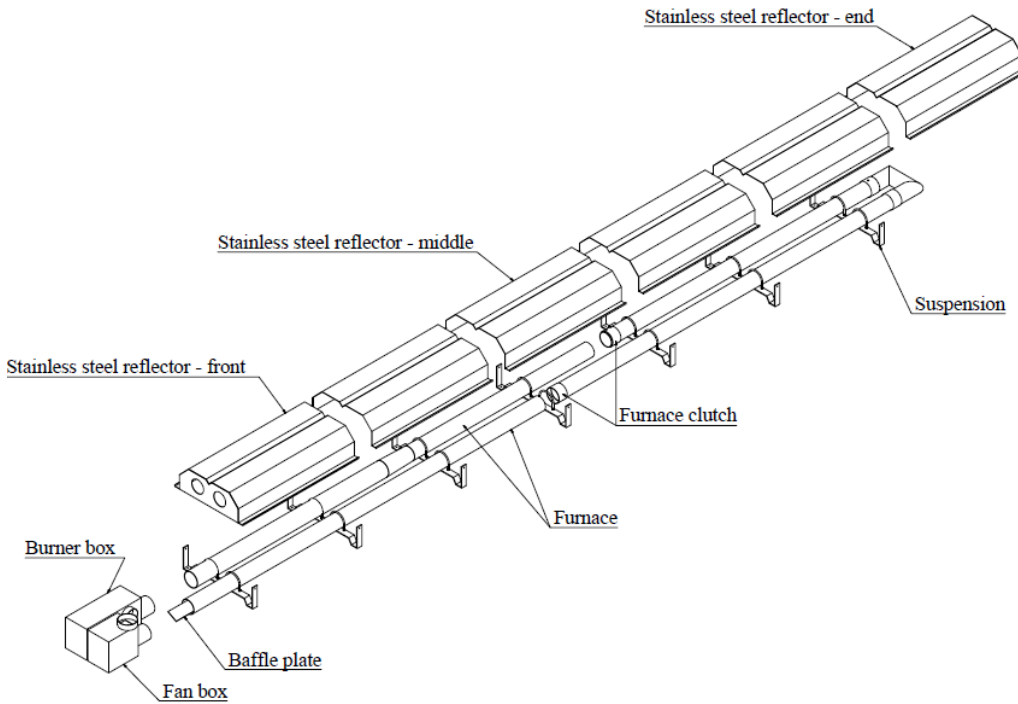
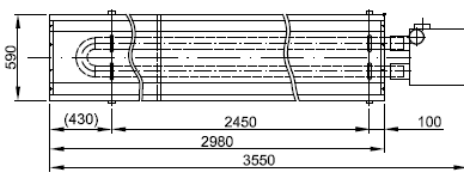

Fig. 3 Infrared heater KM-U with length 10 and 12 m

9. Basic dimensions of individual infrared heaters

In the figure no. 4 are shown basic dimension of individual types of manufactured infrared heaters.

KM 10-U-3m



KM 10-U-4m

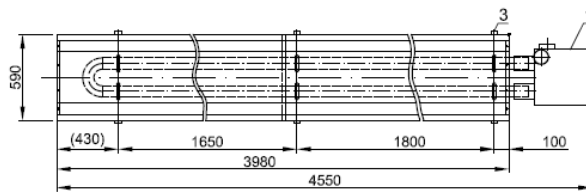

KM 15-U-5m

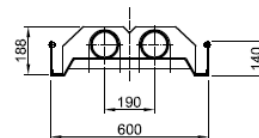
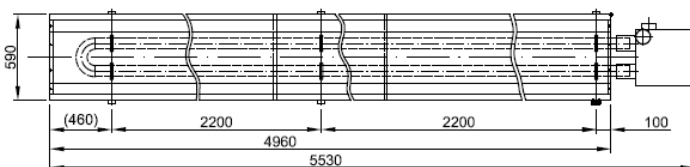

KM 15-U-6m

KM 22,5-U-6m

KM 22,5-U-8m

KM 22,5-U-9m , KM 30-U-9m , KM 36-U-9m

KM 45-U-10m

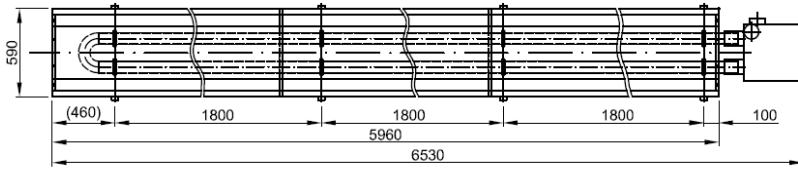
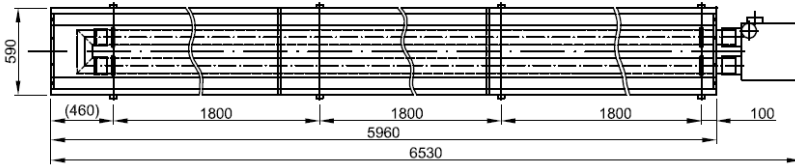
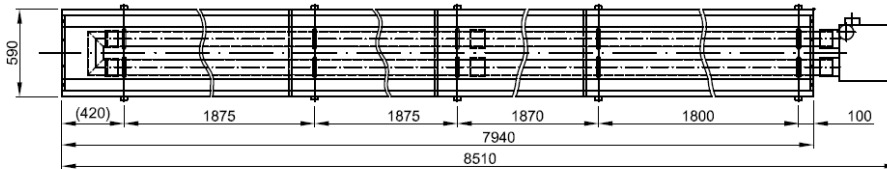
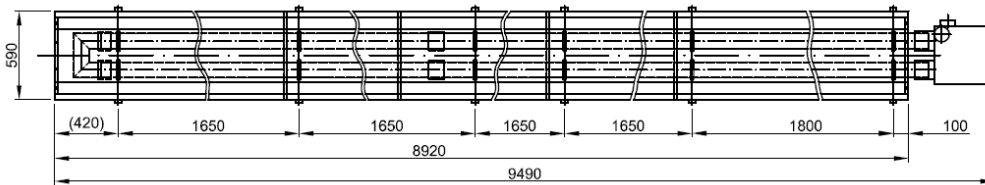
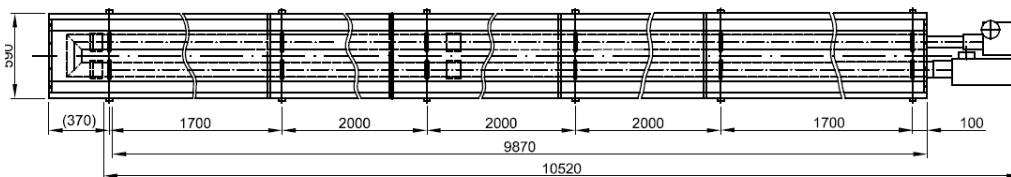
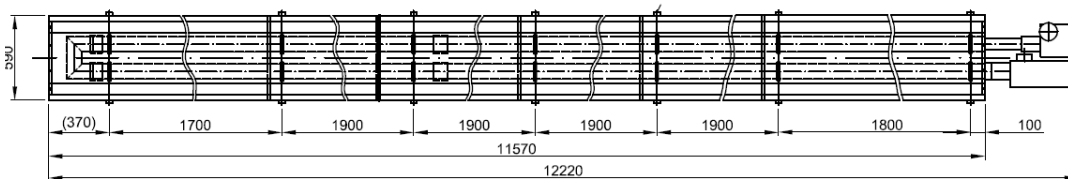
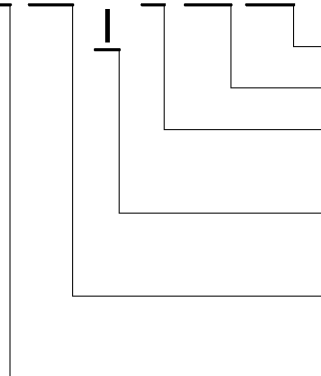
KM 45-U-12m

Fig. 4 Construction variants of tube infrared heaters KM-U

10. Technical data

Infrared heater marking

KM xx-N-U-xx-xx



Nominal length (m)
 Thermal output (kW)
 Furnace shape: U – two tubes

Reflector: N – non insulated
 I – insulated

Nominal thermal output:
 10; 15; 22,5; 30; 36; 45 (kW)

Heater type: Tube (KM)

Tables 1, 2 and 3 gives basic technical data, connection dimensions and operational conditions of individual heaters.

Nominal gas overpressure at the input	– G20 natural gas	kPa	2,0-5,0
	– G30(G31) propane-butane	kPa	3,0-5,0
Gas overpressure at burner	– G20 natural gas	kPa	1,6
	– G30(G31) propane-butane	kPa	2,3
Gas connection into the heater		-	G 3/4“
Degree of electrical protection		-	IP 40
Nominal voltage		V/Hz	230/50
Nominal electrical input (KM10, KM15, KM22,5, KM30, KM36)		W	50
Nominal electrical input (KM45)		W	75
Max. noise at 1 m		dB (A)	55
Flue gas chimney – diameter		mm	100
Combustion air input – diameter		mm	100

Tab.1

		KM 10-U			KM 15-U		KM22,5-U			
Thermal output	kW	7,0	10,0	12,0	14,0	17,0	18,0	20,0	23,0	24,0
Nominal thermal input	kW	7,2	10,7	13,7	15,2	18,6	19,8	22,6	25,7	27,6
Gas consumption:										
- G20 natural gas	m ³ /h	0,72	1,07	1,37	1,52	1,86	1,98	2,26	2,57	2,76
- G30(G31) propane-butane	kg/h	0,56	0,82	1,05	1,16	1,42	1,51	1,73	1,97	2,11
Nominal length	mm	3 000	4 000		5 000	6 000	6 000	8 000		9 000
Total length	mm	3 550	4 550		5 530	6 530	6 530	8 510		9 490
Suspensions	-	2 x 2	3 x 2		3 x 2	4 x 2	4 x 2	5 x 2		6 x 2
Weight – Non-insulated reflector	kg	75	85		105	120	133	165		180
Weight – Insulated reflector	kg	83	96		120	137	150	178		205
Nozzle diameter – G20	mm	2,1	2,5	2,8	3,0	3,5	3,6	3,7	3,8	4,0
Position of air-stop – G20	-	1	3	4	6	7	7	7	9	9
Nozzle diameter – G30	mm	1,5	1,8	2,0	2,1	2,2	2,3	2,5	2,7	2,8
Position of air-stop – G30	-	2	4	5	6	7	7	9	10	11

Tab.2

		KM 30-U		KM 36-U	KM 45-U	
Thermal output	kW	28,0	30,0	36,0	45,0	
Nominal thermal input	kW	31,5	34,1	39,2	48,7	
Gas consumption:						
- G20 natural gas	m ³ /h	3,15	3,41	3,92	4,87	
- G30(G31) propane-butane	kg/h	2,41	2,49	3,01	3,74	
Nominal length	mm	9 000		9 000	10 000	12 000
Total length	mm	9 490		9 490	10 520	12 220
Suspensions	-	6 x 2		6 x 2	6 x 2	7 x 2
Weight – Non-insulated reflector	kg	180		200	220	240
Weight – Insulated reflector	kg	205		225	250	270
Nozzle diameter – G20	mm	4,3	4,5	4,7	5,3	
Position of air-gauge – G20	-	11	11	11	8	
Nozzle diameter – G30	mm	3,1	3,3	3,5	3,7	
Position of air-stop – G30	-	11	11	10	7	

Tab.3

11. Heater's suspension

Suspension is done, depending on local conditions, with surface treated chains of relevant carrying capacity, depends on local conditions (see weight of heaters).

NOTICE! Chains are attached to tube suspensions with M8 screws, because of that it has to have eyes of diameter 8,5 mm - 12 mm.

11.1. Minimum suspension height

Table 4 and picture 5 gives minimum suspension height of the heater in hygienic terms for a standing person. For a sitting person can be adequately lowered.

Type of heater	Output (kW)	A (m)		
		0°	15°	30°
KM 10-U	12	4,2	4,0	4,0
KM 15-U	17	4,3	4,0	4,0
KM 22,5-U	24	4,5	4,3	4,0
KM 30-U	30	4,7	4,5	4,2
KM 36-U	36	4,7	4,5	4,2
KM 45-U	45	4,9	4,7	4,5

Tab.4

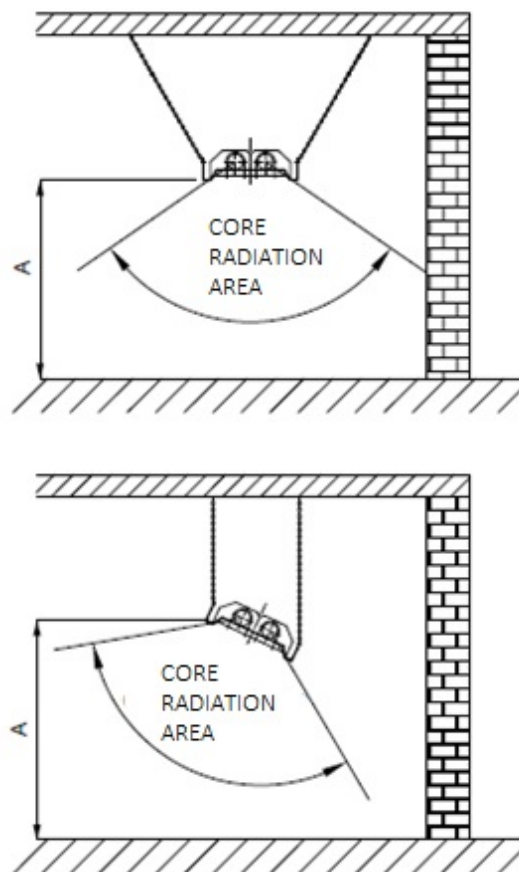

Fig. 5

11.2. Safety distances



Radiating tubes must be arranged in a way to guarantee, that surface temperature of flammable materials in core radiation area does not exceed 85 °C.

This is true, if the distance of flammable materials in core radiation area is higher than 2000 mm (fig. 6). In the picture is also given distance value x from the ceiling structure.

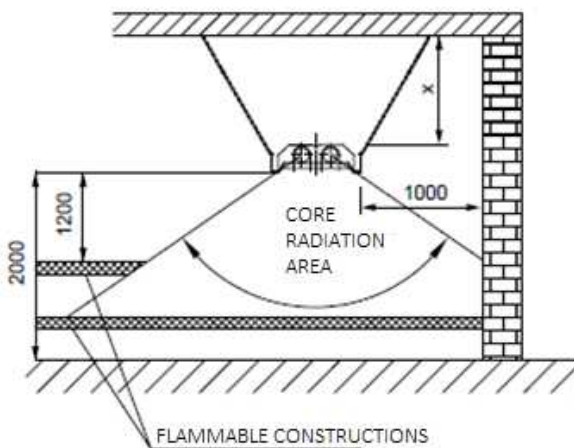

Fig. 6

Horizontal suspension: $x = 800$ mm – flue gas output through the chimney to external environment.

Oblique suspension: $x = 1200$ mm – flue gas output through the chimney to external environment.



Safe distance of flammable construction from the non insulated parts of chimney is **1000 mm.**

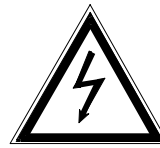

Electrical distribution must be lead in a way, to avoid exceeding its surface temperature 35 °C (inside the core radiation area minimum distance of 1500 mm from the heater, outside of the area minimum 900 mm).

If it is not possible to comply to the given distances, it is necessary to protect flammable constructions and cable distribution with reflexive metal sheets (fig. 7), at best from polished stainless metal sheet. Between metal sheet and construction, there must be a air gap **30 mm** at minimum. In the core radiation area and in the distance up to 1,5 m above the heater there must not be any gas piping! Precise placement of the heaters in terms of fire safety must be included in every design, which addresses a specific local situation.

NOTICE! Special cases or ambiguities is necessary to consult with Kotrbatý company and Fire department authorities.

If there is a crane runway below the heaters, it is necessary to equip it with reflexive metal sheet (see above) in width of core radiation area + 100 mm to all sides. Crane then moves permanently with this cover, which serves as a barrier against radiation for the crane construction and crane control cables overheating. If there are other lifting appliances in the area, it is necessary to heed on all safety rules to prevent damages on appliance or operation personnel health threats.

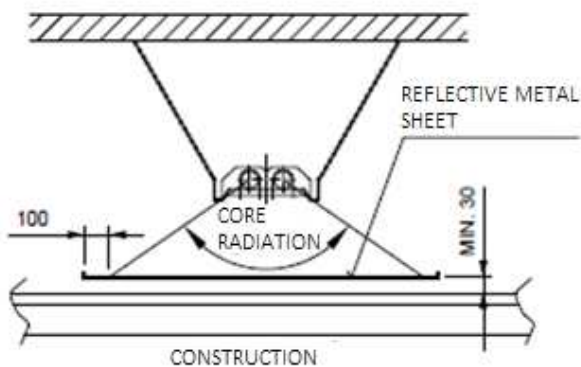

Fig. 7

NOTICE! Radiation tube temperature ranges from 560 to 180 °C (from burner to ventilator)!

12. Gas connection

Connect heaters by attested gas hose for gas appliances connection, union nut G3/4" (to the heater valve), external thread R3/4" (to the gas pipeline), hose 1 m long. Gas supply pipe must be fitted with manual shut-off valve G3/4" – internal thread! Connection of the hose must follow hose manufacturer manual and in accordance to heater dilatation during operation.



Connection hose lifespan is given in its manufacturers manual!

13. Scope of delivery

Heater is delivered unfolded

Delivery includes:

- Radiation furnace with suspensions and baffle plates
- Unfolded stainless reflector with connection material
- Burner box, fan box (KM-U 45 kW only),

KM-U/v.1/EN/2020

connection gas hose

Other elements, as control box (switchboard), parts of chimney, parts of combustion air feed etc. are part of special order.

14. Heater's assembly

Heater assembly manual, assembly rules and warnings are parts of separate appendixes, which are integral parts of this technical documentation.

List of appendixes:

Attachment B1 - Infrared heater assembly manual KM U from 3 to 6 m long

Attachment B2 - Infrared heater assembly manual KM U 8 and 9 m long

Attachment B3 - Infrared heater assembly manual KM U 10 and 12 m long

15. Flue gas venting

Flue gas venting has to be considered in the design. It is necessary to follow all the realted valid standards and regulations in area of operation (ie. in EU: EN 1443, EN 15287-1+A1, EN 15287-2)

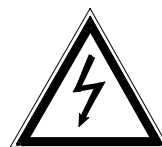

It is necessary to keep safe distance from flammable objects ! (see below)

NOTICE!

It is strictly recommended (in some areas even mandatory) that the operator will have carried out regular cleaning, inspection and revision of the chimney from organisation approved by KOTRBATÝ. This way the lifetime of the devices can be significantly prolonged.

Flue gas venting can be led by chimney through slanting wall of a skylight or a roof, or by chimney through the peripheral wall. Chimney must be controlable, cleanable or must be easily demountable.

Connection of individual parts of chimney must be made of certified elements for overpressure operation. To eliminate risk of ejection, we recommend to ensure connections firmly with rivets or self-tapping screws.

Keep a safe distance from flammable materials (flue gas temperature can rise up to 220 °C, as well as surface temperature of the chimney).

In the figure 8 there is shown typical chimney through the roof O-V, in the figure 8 typical chimney through the peripheral wall O-H.

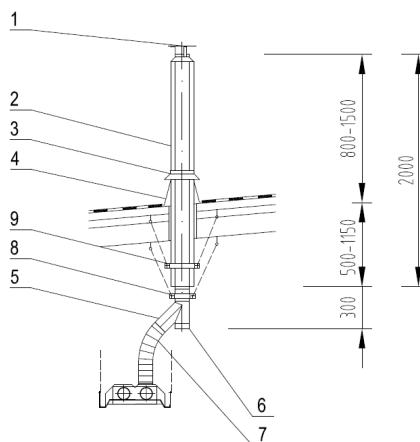

Fig. 8

Basic set O-V (fig.8)

	Item
1 – Meidingers head D100	202.007
2 – Chimney body D100/180	202.009
3 – Water covering D180	202.020
4 - Sheeting D180	202.019
5 - T-piece D100/45°	202.049
6 – Condensation closure D100	202.050
7 - flexo tube Inox D100	202.064
8 – Two piece socket D100	202.034
9 - Two piece socket D180	202.036

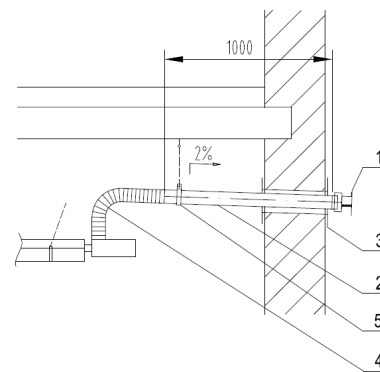

Fig. 9

Basic set O-H (fig.9)

	Item
1 – Meidinger head D100	202.008
2 – Straight pipe D100	202.047
3 – both side shrunk-on D100	202.030
4 – flexo tube Inox D100	202.064
5 – one piece socket D100	202.031

In a reasonable cases, it is possible to connect two heaters on conjoint chimney. It is necessary to secure simultaneous operation of both heaters, to keep sufficient exhaust and prevent flue gas leak.

NOTICE! Finished chimney must obtain identification label (EN 1443), placed at accesible part of the chimney.

16. Combustion air intake

Combustion air inlet, if the operation conditions of heated area permits, can be led in through the roof construction, or skylight construction (vertical type solution P-V in fig. 10) or through the facade of the building (horizontal type solution P-H in fig. 11) or based on individual design. All parts of the feed must be firmly connected.

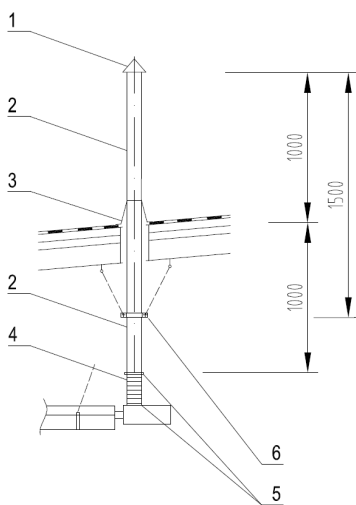

Fig.10

Basic set P-V (fig.10)

	Item
1 – cover of inlet pipeline D100	202.029
2 – straight pipe D100	202.047
3 – rubber pipe sealing collar $\varnothing 76-152$	202.067
4 – flex pipeline Semivac D100	165.051
5 – quick fitting stripe	155.010
6 - Two piece socket D100	202.034

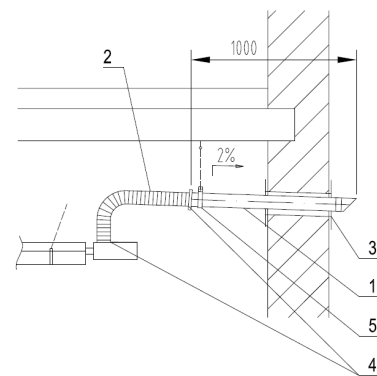

Fig.11

Basic set P-H (fig.11)

	Item
1 – end pipe D100	202.017
2 - flex pipeline Semivac D100	165.051
3 - both side shrunk-on D100	202.030
4 - quick fitting stripe	155.010
5 - one piece socket D100	202.031

17. Infrared heater as a type C appliance

Type C appliance represents appliances where the combustion circle is closed towards the ambient area. Heater in that case features concurrently chimney for flue gas venting and combustion air inlet for the outdoor air. Vertical solution O/P-V is shown in figure 12, horizontal solution O/P-H in figure 13.

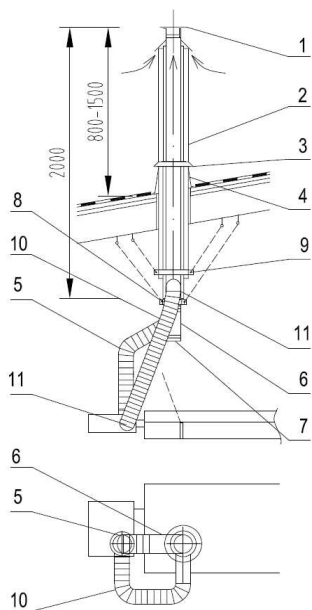

Fig.12

Basic set O/P-V (Fig.12)

	Item
1 - Meidingers head D100	202.007
2 - Chimney body D100/175/250	202.054
3 - Water covering D250	202.044
4 - Sheeting D250	202.045
5 - Flexo tube Inox D100	202.064
6 - T- piece D100/45°	202.049
7 - Condensation closure D100	202.050
8 - Two-piece socket D100	202.037
9 - Two-piece socket D250	202.036
10 - Flexible pipeline Semivac D100	165.051
11 - Quick-fitting stripe	155.010

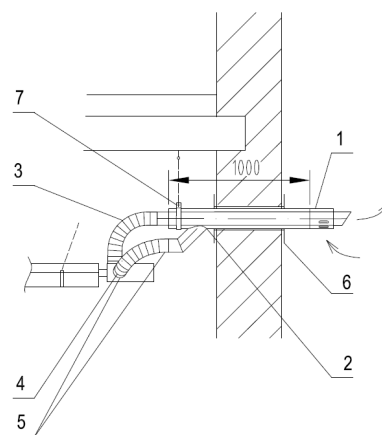

Fig.13

Basic set O/P-H (obr.13)

	Item
1 - Horizontal roof adaptor D100/150	202.060
2 - Chimney combiner D100/150	202.059
3 - Flexo tube Inox D100	202.064.
4 - Flexible pipeline Semivac D100	165.051
5 - Quick-fitting stripe	155.010
6 - Bothside clamping ring D150	202.001
7 - Socket D150	202.032

NOTICE!

Finished chimney must obtain identification label (EN 1443), placed at accesible part of the chimney.

18. Maximum lengths of flue gas venting and combustion air inlet

Type of flue gas venting	KM 10, KM 15, KM 22,5	KM 30, KM 36	KM 45
Type B appliance Combustion air inlet from the heated area			
Vertical O-V D100	14m	12m	12m
Horizontal O-H D100	12m	10m	10m
Type C appliance Combustion air inlet from the outside			
<i>Separated system</i>			
Vertical O-V + P-V(H) D100 + D100	14 m	12 m	12 m
Horizontal O-H + P-H(V) D100 + D100	12 m	10 m	10 m
Max. length of combustion air inlet pipeline P-V(H), D100	5 m	5 m	5 m
<i>Coaxial system</i>			
Vertical O/P-V D100/180	7 m	5 m	5 m
Horizontal O/P-H D100/150	7 m	5 m	5 m

Every other knee 90° shortens max. length of 1 m.

Every other knee 45° shortens max. length of 1 m.

If needed to design flue gas venting over the maximum length, it is necessary to contact manufacturer Kotrbatý.

19. Transportation. Storage

Heaters are delivered prepared for assembly ie. separate burner box, stainless reflector and burner box with heater accessories and gas hose. During the transportation it is necessary to pay heed on proper deposition of radiation tubes (possible protection color rub-off or dents), stainless covers (protect against scratches or mechanical damage) and on protection against weather conditions. Burner box with sensitive automatics needs special KM-U/v.1/EN/2020

care. It is necessary to protect burner box against sudden temperature changes, humidity, dust and impacts.

For transportation is required truck with load area min. 5 m long, sheeted (or with sheets for load cover in a gear) and with compression straps to fix the load.

Dry, lockable place is required as a storage. Manufacturer is not responsible for any damages caused during transportation and storage.

20. Disposal of packaging and product after service life

Non returnable packaging (layerd paper, PE foil) is necessary to sort out and hand to waste disposal organisation.

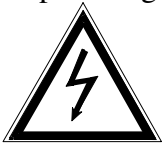

After passing service life (or dismantling) of the heater, it is necessary to disconnect the heater from the electric supply and secure it by authorized person, also it is necessary to close gas valve ahead of the heater, disconnect connection hose and seal the ball valve!!

After end of heaters service life it is necessary to disassembly it and hand it to the waste collection service while:

- Furnace is made from steel tubes
- Reflectors (covers) are made from stainless metal sheet 17 040

We recommend to hand burner box with accessories to Kotrbatý, Pelhřimov, Czech Republic.

Used packaging catalogue no.

Layerd paper 15 01 01

Polyethylene foil 15 01 02

21. Inspections and revisions



Appliance inspections has to be done at least once in a year. We recommend to have two inspections – before and after heating season.

Inspections must be made by qualified personnel (gas + electro qualification) from authorised organisation. We recommend to have inspections done by personel of

Kotrbatý company or personel certified by Kotrbatý.

Ongoing inspections has to be done by personnel appointed by operator to heater operation during whole year (especially during heating season see art. 21)

In case of more often inspections, its dates specifies in local operating rules, depending on technical condition and operational experiences. Air quality control and leak detection is recommended during the inspections.



Revisions are held according to revisions schedule at least once in three years, if other regulations or authorities do not provide otherwise. Gas connection hose is a subject to same revision as gas distribution!!

Electro revisions must be done according to EN 60079-17 ed.4:2014 and related.

CAUTION! Electronical device – Automatics (E.F.D.503) – is installed in the burner box. It is not possible to gauge Resistance – insulation 500 V! Substitute measuring method must be used. Revision technician is not authorized to disconnect heater from the gas hose during the revision, because it will be taken as an intervention in the gas appliance!!

NOTICE!

It essential to follow safety rules during activities listed below!!!

Moreover, it is work in heights!



Workers must have certificate of yearly regular training and medical examination!!!

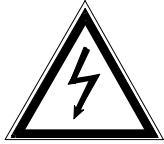

Activities listed below bear risk of electric shock and burn (from flue gases or heaters body). It has to be performed only by trained personnel with qualification listed in appendix B!!!



As a part of heater inspection and maintenance it is necessary:

- To check tightness of all gas joints from ball valve ahead of heater to the nozzle in burner box. We recommend to use personal gas detector.
- To check gas hose (if it is not damaged or tensioned)
- To check intactness of radiation tubes (if it is not burned)
- To check suspension of the heater (state of chains and screws, anchoring into the supporting construction)
- Wipe off dust from the burner box and stainless cover
- Wipe ignition and ionization electrode, check connecting of these electrodes to the cables
- Start the heater and measure gas pressure on the nozzle – if the value does not accord, set the pressure on prescribed value.
- Check the tightness of the measuring probes at gas valve. We recommend to use personal gas detector
- Check controls of heater (function of control box, thermostat and switchgear)



After inspection and maintenance it is necessary to start heater repeatedly!!!

22. Spare parts

Name	Code
Ignition electrode	0774920
Ionization electrode	0774781
Ignition cable	CV 22011
Ionization cable	CV 22004
Gas valve	0 830.035
Automatic control	0 503.501
Gas hose	020 GG 121
Radiation tube	010 1 02 04
Stainless cover	010 1 01 22
Nozzle	010 1 07 01



Change of defective parts can be performed only by qualified personnel (gas + electro qualification) from authorised organisation. We recommend to have the changes done by personnel of Kotrbatý company or personnel certified by Kotrbatý.



After change of defective parts it is necessary to start heater repeatedly!!!

Change or repair of parts not specified as a spare ones, has to be consulted with manufacturer of heater!

Fault finding

Only qualified personnel according appendix B of this documentation!!

Before every fault diagnostics it is necessary to check, if there is sufficient gas pressure ahead of the heater, if there is appropriate voltage on electric supply and if there is appropriate pressure at the nozzle!!!

Fault	Cause
Heater starts up, goes off after while	- non functional ionisation electrode - faulty ionisation cable - control automatics fault
Heater does not start, but ignition electrode sparks	- control automatics fault - fault gas valve
Heater does not start, and ignition electrode does not spark	- fault air manostat - fault ventilator - fault ignition electrode - fault ignition cable - control automatics fault

23. Operation

For operation, inspections and revisions, operational logbook and operation of gas appliances see valid local standards and regulations. Operation of the heater can be done only by personnel authorized by operator, who were provably introduced to its operation, control and regulation system, safety rules and local operating rules. Instructions for control and regulation system are given by installing organisation.



Any interventions to the appliance are forbidden!!! (If needed, call service organisation)

organisation)

Maintenance obligation

Each worker operating heater must know:

- Local operating rules
- Safety rules
- Control system (regulation)
- Location of gas, water and electricity main closure
- Location of separate manual gas closures ahead of each heater

Worker is obligated:

- Visually check smooth running of the heater after the ignition
- Green indicator = operation
- Red indicator = fault
- Execute two more starts using deblocking if the flame extinguish or heater does not start up (red indicator lights)
- Once in a three weeks perform visual check of heaters – check first meter of radiation tube for „reddening“ (side near to the flame), flaking or burn-throughs, check burner box for damages (curled to side, ripped front side), check if the heater is hanged horizontally, if the furnace parts are well connected, if the flue gas outlet is undamaged, if the stainless reflector does not went out of its initial fitting etc.
- check gas connection hose if it is not tensioned (see hose manufacturers instructions for assembly)
- if any fault or damage was found, immediately make safety measures and call service organisation



Never operate damaged heater!!! Gas appliance operator is obliged to perform safety measures after finding of gas leak to prevent safety hazard for people and property!!!

In case of heater shutdown for a period longer than 1 month, shut off main gas closure on the route to the heaters or gas valve ahead of the heater!

After every maintenance it is necessary to turn the heater on!!

Turning heater on and off

Heater can be operate only by personnel fulfilling requirements from article 22. During training of the personnel by service technician is trained person acquainted with installed control system.

Control can be manual or automatic (temperature, time or combined regulation) with possible manual turning on and off.

If the heater do not start up or turn off shortly after the ignition, operation personnel deblocates heater by using deblockation button of the relevant heater on control box.

If the heater does not turn on even after several deblockations (max. 5x), operation personnel should:

- ⇒ turn off relevant heater at the control box
- ⇒ close gas ball valve ahead of the heater



Work above 1,5 m from the floor is classified as a work in heights – worker who is closing the gas valve at the heater level must have according training and regular medical check!

- ⇒ On the switch of relevant heater puts a label „Out of service – do not turn on!“
- ⇒ Informs service technician (see art. 24)

Operation personnel must not interfere into the control box!!!

24. Local operation rules

Operator of gas infrared heater KM is obliged to write local operation rules:

- a) Basic requirements:
- Title list
 - Table of contents
 - Address and telephone number of gas company holding emergency, fire department, emergency medical services, electricity company, technical service of Kotrbatý
 - appliance basic technical values
 - short characteristic of used gas
- b) Other requirements:
- Basic scheme of gas part
 - instructions for regulation and operation of heaters
 - Art. 12.1. of this documentation, setting operation personnel obligations
 - Instructions for security and other devices (if installed)
 - Instruction for leak search including terms
 - Terms of air control
 - Type of operation (permanent, occasional etc.), names and contacts of operation personnel
 - Operation instructions
 - Instructions for decommissioning
 - Instructions for case of fault or an accident
 - Terms of inspections and revisions
 - First aid instructions
 - special requirements according to local conditions

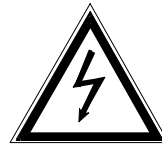

Before beginning of any works, possibly changing external effects in heated area (for ex. Work with paints, adhesives, wood etc.), it is necessary to decommission heaters for the period. Setting back into operation can be done just after the parameters of surrounding environment are in original state.

If the change of external effects will be permanent, it is necessary to provide new determination of effects in the area by authorized person, who decide, if the heaters can be operated. (see art. 5 of this documentation).

25. Contacts

KOTRBATÝ V.M.Z. spol. s r.o.

Sales and design

Polívkova 538/30
158 00 Praha 5
Czech Republic
tel.: +420 245 005 921
email: kotrbaty@kotrbaty.cz

Manufacture, service

Sdružená 1788
393 01 Pelhřimov
Czech Republic
tel.: +420 564 571 520
email: vyroba@kotrbaty.cz

26. Notifications

ATTENTION !



GAS APPLIANCE – a product specified under the provisions of Czech Rep. Act No. 22/1997 Coll. and Governmental Decree No. 177/1997 Coll.

Assembly of gas fired infrared heater must be done strictly by the enclosed assembly manual!!!

This appliance must be installed in accordance with valid guidelines and its use is allowed only in well vented area. Before assembly and commissioning it is necessary to read the manuals.

Power cords end in electrical ACIDUR box with the wreath cca 1 m from the burner!

Before commissioning of the heater:

- Provide revisions of gas and electricity (copies give to service technician)
- Fill gas piping with gas and perform air venting

In case of any problems, contact manufacturer:

+420 245 005 921

27. Mandatory info according to Commission Regulation (EU) 2015/1188

Model identifier(s):	KM10 - N - U, KM15 - N - U, KM22,5 - N - U, KM30 - N - U, KM36 - N - U, KM45 - N - U
Heater type:	Tube radiant heater (not insulated)
Fuel:	gaseous – natural gas G20

Model identifier(s):			KM 10-N-U			KM15-N-U		KM22,5-N-U				KM30-N-U		KM36-N-U	KM45-N-U	
Item	symbol	unit	value													
Heat output																
Nominal heat output	P_{nom}	kW	5,9	8,8	11,3	12,5	15,3	16,3	18,6	21,1	22,7	25,9	28,0	32,2	35,5	40,0
Minimum heat output	P_{min}	kW	Not applicable													
Nominal heat input	Q_h	kW	6,8	10,1	12,9	14,4	17,6	18,7	21,4	24,3	26,1	29,8	32,2	37,0	40,8	46,0
Useful efficiency (GCV)																
Useful efficiency at nominal heat output	$\eta_{th,nom}$	%	78,3	78,3	78,3	78,3	78,3	78,3	78,3	78,3	78,3	78,3	78,3	78,3	78,3	78,3
Useful efficiency at minimum heat output	$\eta_{th,min}$	%	Not applicable													
Space heating emissions																
Space heating emissions NO _x	$mg/kWh_{input(GCV)}$		150	150	150	150	150	150	150	150	150	150	150	150	150	150
Radiant factor																
Radiant factor at nominal heat output	RF_{nom}	-	0,70	0,67	0,63	0,64	0,64	0,62	0,67	0,63	0,64	0,61	0,59	0,57	0,57	0,58
Radiant factor at minimum heat output	RF_{min}	-	Not applicable													

Model identifier(s):			KM 10-N-U			KM15-N-U		KM22,5-N-U				KM30-N-U		KM36-N-U	KM45-N-U	
Item	symbol	unit	value													
Auxiliary electricity consumption																
At nominal heat output	eI_{max}	kW	0,090	0,090	0,090	0,090	0,090	0,090	0,090	0,090	0,090	0,090	0,090	0,090	0,175	0,175
At minimum heat output	eI_{min}	kW	Not applicable													
In standby mode	eI_{sb}	kW	0,000	0,000	0,000	0,000	0,000	0,000	0,000	0,000	0,000	0,000	0,000	0,000	0,000	0,000
Permanent pilot flame power requirement																
	P_{pilot}	kW	Not applicable													
Envelope losses																
Envelope insulation class	U	W/m ² K	Not applicable													
Envelope loss factor	F_{env}	%	0,0	0,0	0,0	0,0	0,0	0,0	0,0	0,0	0,0	0,0	0,0	0,0	0,0	0,0
Heat generator to be installed outside the heated area	-	-	NO	NO	NO	NO	NO	NO	NO	NO	NO	NO	NO	NO	NO	NO
Heat output control type																
Single stage	-	-	YES	YES	YES	YES	YES	YES	YES	YES	YES	YES	YES	YES	YES	YES

Separate attachment A

Appliance documentation

INFRARED HEATERS' NAMEPLATE



VÝROBNĚ MONTÁŽNÍ ZÁVOD, SDRUŽENÁ 1788
393 01 PELHŘIMOV, CZ

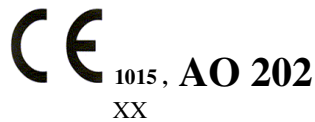

Infrared heater, type KM	-	
Serial number	-	
Nominal output	kW	
Nominal input	kW	
Fuel type	-	
Fuel consumption	m ³ /h	
Connection overpressure-min.	mbar	
Connection overpressure -max.	mbar	
Pressure on nozzle	mbar	
Country of appliance destination	-	
Appliance category	-	II _{2H3B/P}
Class NO _x	-	2
Total appliance weight	kg
Voltage	V	230
Power input	W
Frequency	Hz	50
Degree of protection	-	IP 40
Year of manufacture (XX at CE)	-	

WARRANTY LIST OF INFRARED HEATER KM

We guarantee the quality, operations and design of this KM heater for the period of **two** years from the commissioning date and **three** years (at maximum) from the date of purchase, provided that the heater is:

1. installed and operated according to the current installation and operation recommendations of the manufacturer and relevant technical standards,
2. not mechanically/forcibly damaged,
3. in the original state without any modifications, repairs or unauthorised handling,
4. originally commissioned by KOTRBATÝ specialists or authorized organisation

Type:

Serial No.:

Date of purchase:

Commissioning date:

Commissioned by:

.....
manufacturer's seal and stamp

.....
dealer's seal and stamp

The appliance has been installed by (company):

On:

KM tube infrared heaters are certified by the authorised laboratory - SZÚ 202 Brno; Certificate No. E-30-00510-03 rev.2. The manufacturer issued Declaration of Conformity for this product pursuant to Czech Rep. Act No. 22/1997 Coll. as amended later.

KOTRBATÝ V.M.Z. s.r.o.

Adresa: Sdružená 1788, 393 01 Pelhřimov

tel.,fax: 564 571 520-2

TEST PROTOCOL

Gas appliance – infrared heater KM

Type of infrared heater: KM

Serial number:

1. Test of completeness and correct assembly of the burner box

Checked according to internal regulation KP 06/01

qualifies

2. Functional test

Completely checked according to internal regulation KP 06/01

qualifies

3. Test of tightness of the heater burner gas system

- Tightness test of welded joints
- Tightness test of screw joints
- Tightness test of gas probes

qualifies

qualifies

qualifies

Tightness tested with gas detector according to internal regulation KP 06/01

Overall results of the tests: qualifies (device is capable of putting into operation)

Tests conducted:

Pelhřimov, date

.....
Stamp, signature